

Thomas Harriot: the first telescopic astronomer

Allan Chapman

A revised and expanded text of the 2007 Christmas Lecture, given at the Mermaid Conference Centre, Blackfriars, London EC4 on 2007 December 15

I am going to devote the 2007 Christmas Lecture to Thomas Harriot. I think it is appropriate to do so because next year, 2008, will be the 400th anniversary of the invention of the telescope, by Hans Lippershey, Zacharias Janssen, and perhaps other Dutchmen. And although the principles of the instrument were first made public in 1608, it was at least eight months before anybody recognised that it possessed any scientific potential. For at first, the telescope was used as a military or naval device, or regarded purely as a novelty.

As far as we can tell from the historical record, however, it was Thomas Harriot who became the first person to look at an astronomical body through a telescope, on or before 1609 July 26, when he came to realise that the image of the Moon produced by it was very different from what was seen by the naked eye, although he did not publish his discovery. Galileo Galilei, on the other hand, did not observe an astronomical body with the telescope until late November or December 1609, but he instantly recognised the significance of his discoveries, and published them in March 1610. Yet Harriot made no counter-claims when he subsequently read Galileo's *Sidereus Nuncius*, and his work as an astronomer was largely unknown until 1785, when the visiting German astronomer, the Count de Brühl, examined his writings, recognised their significance, and with his friend the scientific Baron von Zach, gave notice of their importance in Germany, and recommended that they should be published.

But it was not until 1833, when Stephen Peter Rigaud, Savilian Professor of Astronomy at Oxford and Director of the Radcliffe Observatory, was preparing for publication the works of the Revd Dr James Bradley, one of his professorial predecessors and Astronomer Royal some 70 years before, that anything further was done. Rigaud added a supplement to Dr Bradley's *Miscellaneous Observations*, which included several sheets of Harriot's discoveries, though these were little more than a 'taster' for what survived. The original Harriot manuscripts are now preserved in the British Library, following their donation to the British Museum by Lord Egremont in 1810, and at Petworth House in Wiltshire. But it was Rigaud's work that really alerted English readers to the significance of Harriot's writings.

Of course Harriot was far from being an unknown figure in 1610, for he already had an illustrious reputation as a European mathematician, a pioneer of algebra, and a skilled planetary calculator. His subsequent angular measurements of the great comet of 1618 were of the highest mathematical value, as will be shown presently. Harriot's mathematical astronomical work was known, at least amongst mathematicians even if not



A purported likeness of Thomas Harriot, based purely upon an early 20th century attribution. But following the portrait being cleaned in 1957, an age for the sitter – 32 – was revealed, which would have been a decade out for Harriot in 1602, when the face picture seems to have been painted. Nonetheless, this is the face that has been claimed as Harriot's for much of the 20th century.¹ Original in Trinity College, Oxford.

in published form, from letters, some of which were later published, for Harriot corresponded with several European astronomers, including Kepler. His telescopic observations, however, were a whole thing unto themselves, and their announcement was quite revelatory after 1832–'33, in spite of the German announcements of 50 years before.

Harriot's background and education

Before looking at Thomas Harriot's achievement, let us say something about the world in which he lived. He was born in 1560, a native of the City of Oxford. We know nothing about his parents, his father's profession, or the background of his mother. We do not even have a firm birth-date for him within

the year 1560. We are told that he went up to St Mary's Hall, which was one of the medieval halls of Oxford University adjacent to and later absorbed by Oriiel College. That is why Oriiel now claim Harriot as one of their own, and in 2007 commissioned a copy of a portrait, allegedly of Thomas Harriot and now owned by Trinity College, Oxford; this copy currently hangs in Oriiel's dining hall. There have, however, been doubts expressed as to whether the face appearing in the early-seventeenth-century portrait really is that of Harriot.¹ The portrait shows a man, probably in his thirties, dressed in black and wearing a large starched ruff collar. He looks thin, and tense almost to the point of suspicion, epitomising the 'reserved' and 'melancholy' temperament mentioned by contemporaries, and holds in his hand a scented pomander ball, which people often carried in time of plague in the hope of driving the stink of disease away.

We do not quite know how Harriot got into St Mary's Hall, although he was certainly a native Oxford lad. Perhaps he had attended one of the numerous private schools operating in Oxford in those days, because it would have been necessary, before going to university, to have had a very thorough preparation, especially in Latin, Greek, classical studies, and the lower branches of mathematics; though this would not have been hard to come by in Queen Elizabeth I's time. For in this post-Reformation period numerous 'grammar schools' were founded across the length and breadth of England, usually by rich, public-spirited Protestants, and with handsome endowments to pay for scholarships for bright boys from poorer backgrounds. The Tudors fully understood the need to encourage talent irrespective of the social background of the individual. The great Cardinal Wolsey, three or four generations earlier, had been the son of an Ipswich butcher and a scholarship boy to grammar school, Oxford, and the Bar.

Nobody went to university in the sixteenth century, however, to read for a specific degree, as they do today. Instead, everyone took what was called an Arts degree, which would have included a lot of Latin and Greek literature, philosophy, history, grammar, logic, rhetoric, and so on; a good bit of Protestant theology (after the death of the Catholic Queen Mary in 1558); perhaps the basic principles of the English constitutional and legal system; and mathematics. Mathematics would have been seen as complementing the logical literary disciplines, in so far as mathematics taught a young man how to reason, argue, and calculate: essential skills for men entering public life. And grammar taught you how to use language accurately, and lay at the heart of precise communication. For if you could not speak with an agreed logical precision, you could not communicate complex ideas. The grammar taught in these schools would have been Latin – and Greek – grammar. On the one hand, such a linguistic training would have given an individual access to those classical, medieval, and Renaissance writers whose works established the intellectual and spiritual foundations of Western civilisation. And from the wider intellectual discipline implicit within classical scholarship evolved the literary vernacular languages of Europe. Foundational documents such as Shakespeare's plays, the *Book of Common Prayer*, and the Authorised Version of the Bible all sprang from this common intellectual tradition based upon clear and well-argued speech.

And mathematics complemented it, for mathematics was a study of pure objective truth. The theorem of Pythagoras and the geometry of Euclid cannot be falsified. And the very nature of the abstract power of arithmetic was unfalsifiable: two and two always make four, irrespective of two and two what, for the concepts have a unique and eternal power.

So the purpose of an education was to give you intellectual flexibility, with a focused power of linguistic communication on the one hand, and a capacity to cut through logical problems with mathematics and precise thinking on the other. Some people may say that 'In the past, they studied a lot of subjects irrelevant to everyday life that had no bearing on anything useful.' But I must disagree. For if you can think accurately, argue logically, and use numbers precisely, you can get a job. It is a different priority, however, from that of imparting a currently-fashionable skill, for being able to use your brain flexibly and creatively is rather important in the workplace.

Yet when a student in Harriot's time took the degree of Bachelor or Master of Arts, it was not like today, where you have written examinations and first-, second-, and third-class results. The whole examination process was conducted by means of an oral *viva voce*, 'living voice', examination, which did not involve swotting followed by hours of writing, so much as arguing directly with your tutors and examiners about specific set questions. It was a system that favoured the well-stocked memory, the quick, agile brain, and the logical gymnast. Useful skills if one were going to enter Parliament, the law, the Church, or the Civil Service, which were the most likely occupations that Oxford and Cambridge graduates would have aimed for in those days.

So this is the system that Harriot would have gone through, and which would have left him, at the age of about 19 or 20, with a degree, and a well-trained mind. But then, how did a Tudor graduate set about finding a job?

Patronage and culture in Tudor England

Now let us leave Harriot for a while, and look at what was going on in England around the time of his birth, or at his graduation from St Mary's Hall; for England at that time was a rapidly-moving country. The Tudors were on the throne, and King Henry VIII, who had reigned from 1509 to 1547, had been one of the most intelligent monarchs we have ever had. Yes, King Henry had his drawbacks: he was a womaniser and an autocrat, and grew increasingly bad-tempered, to name but a few of them; but he had a first-class brain, and was fascinated by literature, theology, geography, music, and many other aspects of Renaissance culture. His children also had brains, and his only son Edward VI, who died of tuberculosis at the age of 16, had shown himself to be exceptionally intelligent, and was used by his constitutional guardians and tutors to advance the English Protestant Reformation. When Edward died in 1553, his sister Mary ascended the throne.

Mary was a woman of fine intellect, but her heavy-handed attempts to reverse the Reformation and bring England back

to the Roman Catholic faith were a disaster, and created an English prejudice against Catholicism which would endure for centuries. Elizabeth, the famous Good Queen Bess of legend, succeeded her half-sister Mary, and reigned from 1558 to 1603, from the age of 25 to just short of 70. Now Queen Elizabeth I was also one of the most intellectually-gifted and astute monarchs ever to have sat on the British throne, and in that respect she took after her father. She wrote Latin and Greek fluently by the time she was 12. She had excellent French, Italian, and Spanish, which were important accomplishments for a monarch, who would need to be able to communicate with visiting ambassadors and speak with them in Latin or in their native tongues. Like King Henry, she was interested in literature, philosophy, theology, and the life of the mind. And of course, we know her perhaps most familiarly from the iconic speech delivered at Tilbury to the English troops preparing to defend the realm against the Spanish Armada in 1588.

The royal court and the City of London

Elizabeth liked to have very clever – and brave – people around her. Her court was full of clever folk: musicians, scientists, theologians, poets, philosophers, cultured soldiers and sailors, explorers, and mathematicians; and one man in particular was to have a major influence upon some of the young men around her. This was the famous Dr John Dee. Dee of course was known as a mathematician, as well as being an occultist, raiser of spirits, talker to the dead, and practitioner of all sorts of strange and exotic arts. But he also wrote a great manifesto for mathematics in the English language. In 1570, he wrote the ‘Mathematical Preface’, to the first-ever English translation of Euclid’s *Geometry*, done by Henry Billingsley. Indeed, Dee’s ‘Preface’, together with other statements by him, acted as a sort of clarion call to the English about the power of mathematics and applied geometry. They would, he claimed, facilitate good navigation, the discovery of foreign realms, the mapping of the world, and, very importantly, the continued growth and prosperity of the City of London, its trade, and its merchants.² Blackfriars Wharf, which would then have been just down the way from where this lecture is being delivered, was one of several major landing stages on the long waterfront of old London on the north bank of the Thames, receiving imported goods from across the globe.

The City, of course, was the mercantile quarter of London. The royal Court would have been at Whitehall in the City of Westminster, more or less where the government offices are now, in the long-vanished great palace which stood to the north of Westminster Abbey. London, indeed, was an intimate community of merchants, tradesmen, courtiers, and scholars. The Temple, two tube stations west of where I am now speaking in the modern city, was where the lawyers had already practised for nearly 400 years in 1580, and they are still there. The national law courts held in Westminster Hall,

the government machine in Whitehall, the royal palaces, and the money-making centre of the nation in the City itself – were all stretched out along two miles of the Thames’s north bank, from the Tower to Westminster, with the Archbishop of Canterbury’s palace (then itself a centre of the nation’s administrative machine) just across the river at Lambeth.

Here lay the heart of the nation’s power of patronage. For the City traded with all the known world, from China to Hudson’s Bay; and Sir Thomas Gresham’s great Royal Exchange of 1570 was, in its rebuilt form, to remain one of the enduring instruments of English mercantile enterprise down to the present day. And following the death of Lady Gresham in 1597, Sir Thomas’s Will came into force, by which his great mansion on Bishopsgate became Gresham College, with seven resident Professors (including chairs in Astronomy and Geometry), liberally funded from Gresham’s fortune and administered jointly by the Mercers’ Livery Company and the City itself. Gresham College was itself a visionary place – the world’s first college of adult education, in fact. It had no matriculated students, though anyone could (and still can) walk in off the street to hear the lectures of the Professors, and all free of charge.

And, of course, Oxford and Cambridge, England’s only universities in 1580, were constant feeders of clever young men into this world and into Gresham Professorships. At this time too, Dee was not only one of the leading lights of English intellectual life and the foremost encourager of mathematics; he was, in addition, something of a visionary in the way he saw mathematics as opening up the globe to navigation, exploration, and trade, not to mention glimpsing England’s potential as a major maritime power. It is also true that he had men around him in his circle who were Copernicans.

Copernicanism in England

Now let me say something about Copernicus, because Harriot himself became a Copernican. Tudor England provided fertile soil for Copernican ideas, and one finds several sympathisers of the Heliocentric theory in the wider circle around John Dee. One of them was Thomas Digges, son of the practical mathematician Leonard, who as an orphan had been a ward of Dr Dee. Thomas Digges was a mathematician, an Oxford graduate, a Kentish gentleman, a distinguished soldier, and a magistrate, who in 1576 updated and produced an English version of a book originally published by his deceased father. This book was entitled *A Prognostication Everlasting*, that is, a perpetual calendar, which enabled you to calculate, let us say, the date of Easter for a hundred years hence, and various other useful things in calendrical astronomy. But crucially important was a short supplement which Thomas added, entitled a ‘Perfit Description of the Caelestiall Orbes’; for that supplement was the first clear statement of the theory of Copernicus in the English language. It was centred upon a detailed engraving of the solar system: the Sun was in the centre, surrounded by all the planetary orbs, along with an English text describing the theory of Copernicus.

Yet very significantly, instead of the stars beyond Saturn being depicted as equidistant from the centre upon a sphere, as was traditional, Digges depicts them as extending upwards to infinity in all directions and filling the corners, or 'spandrels', of the page. Indeed, he appends a text to this three-dimensional star system which reads: 'This orbe of starres fixed infinitely up extendeth hit self in altitude sphericallye, and therefore. Immovable the Pallace of Foelicitye garnished with perpetuall shininge glorious lightes innumerable. Farr excellenge our Sonne both in quantity and qualitey the very court of coelestiall Angelles devoid of greefe and replenished with perfite endlesse love the habitacle for the Elect', or Heaven. So the universe is full of stars until you get to Heaven. There is even the suggestion too that our Sun is not unique. Could the stars in the sky be distant suns? (But let us not forget that this idea had been floated over a century before, by the scientifically-minded Cardinal Nicholas of Cusa, in Germany.) And all of this was being published while Harriot was a 16-year-old schoolboy, and before he matriculated at St Mary's Hall in 1577.

Now this gives you something of the flavour of what was going on in England at this time. Many of the men I have been talking about were connected in one way or another to the royal court, many to the City of London, and most of them were university graduates. And did any of them get into any kind of religious trouble for harbouring these ideas? No! Nobody, as far as I am aware, got into any hot water whatsoever for their *scientific* beliefs. The things that *would* have got you into hot water 400 years ago were seditious and treasonable activities: such as attempts to overthrow the state, kill the Queen, or attack the basic principles by which English life was lived. That is what would have got you arrested. But as far as science was concerned, you could, if you did not mind being laughed at, believe that the moon was a lump of green cheese, and nobody would touch you for it. In other words, there was no persecution at all for scientific subjects. It was attacks upon the Queen's person, her ministers, Parliament, and the Queen's Peace and the realm of England that got you sent to the Tower in Elizabethan times. Astronomy, quite simply, was regarded as free intellectual space in England. And pretty well all the Gresham Astronomy Professors after 1597 were Copernicans: Henry Briggs, Henry Gellibrand, John Greaves, Sir Christopher Wren, Robert Hooke, and so on.

Thomas Harriot's early career

Having given you this background, I shall now return to Harriot, for he was a child of the above-mentioned world. Now if around 1580 you had obtained an Oxford or Cambridge degree, as he did, how did you go about getting a job? You certainly did not apply to company advertisements, for there were none; rather, you tried to catch the eye of what was called a 'patron', for a patron was somebody who would take you under his wing (or, in the case of the Queen or a great lady, her wing), and give you some kind of job. Harriot by

some channel entered the service of Walter Raleigh, who in 1580 was a rising star of Queen Elizabeth's court, as well as being a distinguished graduate of Oriel College, Oxford: the academic institution next door to Harriot's St Mary's Hall, which had some kind of supervisory connection with the Hall. So one suspects that, while Harriot and Raleigh were eight years apart in age, and would never have been contemporaries at Oxford, the 'old boys' network' could have drawn the scientific sea-captain's attention to the young St Mary's mathematician. For what contemporary sources tell us is that Harriot was taken into the Raleigh 'household' for his skill in mathematics, and his ability to teach it to sea-captains.

Who was Walter Raleigh? Well, of course there is the popular image of him: throwing his cloak down for the Queen, fighting to defend England against Spanish aggression, and being Her Majesty's court favourite. Yes, he was all of those things. But he was also an accomplished and deeply-learned scholar: a linguist, poet, philosopher, astronomer, and a man of diverse learning, as well as being an established national hero and a man of action. When, therefore, you were taken into the entourage of Sir Walter, you were doing well, with potential access to money, patronage, clout, and maybe a connection to the royal Court. For the Queen doted on Sir Walter, and was probably in love with him. She liked his conversation, and his wit and courage. But she hit the roof in 1592, when she discovered that Sir Walter had made a secret marriage with Elizabeth Throckmorton, one of her ladies in waiting; for although the Queen was 59 at the time and Raleigh 40, she did not like her young favourites slinking off to get married behind her back.

England and the global situation

This is the circle in which Harriot was moving by his early thirties, and while in no way a courtier, it is not unlikely that he had met Her Majesty. It was a circle not just intellectually distinguished, but also concerned with the strategies of national defence in time of crisis, and with planning the global expansion of English sea power. So let us look at the international situation in the 1580s, and at how Britain tried to cope, for Spain was emerging as the world's first global superpower, and in 1581 came to dominate the whole of the Iberian peninsula, following her annexation of Portugal. Spain also ruled the Netherlands, Belgium (in those days what we would now call Holland and Belgium were called the 'Spanish Netherlands'), and the whole of the American continent virtually from modern California and Texas down to Peru, then across the Pacific to the Philippines, the Malayan island chain annexed by Spain and named after Philip II.

The Spaniards were producing immense amounts of bullion from the Americas, the Spanish plate and treasure fleets were crossing the Atlantic and Pacific, while the dominating foreign policy of the absolutist King Philip II was to reverse the Protestant Reformation. Having failed to re-impose the Catholic faith in England and northern Holland diplomatically, King Philip resolved to do so by military and naval

means, employing his brilliant and brutal star general, the Duke of Alva. England, of course, did not have the ships, the manpower, or the resources to go in for a full frontal fight with Spain. What we resolved upon was a form of guerrilla tactics. Attack the plate fleet at sea if chance allowed, burn Cadiz, sweep down and attack key Spanish installations in the Caribbean and Mexico, and in 1579, seize the rich Pacific galleon *Cacafuego*, and bring home a fortune for Sir Francis Drake, his men, and the Queen. And of course Sir Walter Raleigh, along with Sir Francis Drake and others, were dab-hands at such lightning strikes, for Raleigh was a brilliant cut-and-run pirate when he needed to be, attacking Spanish power where it hurt. So this was the man who became Thomas Harriot's patron and friend.

In the early 1580s, England was planning a colony or settlement on the east coast of North America. And in addition to colonising as such, a secure base in that part of the Continent, which they named Virginia, after the virgin Queen herself, would be an ideal place for English vessels attacking Spain in the Caribbean to resort to, repair battle damage, and refresh without having to face the long haul back to Devon. Raleigh had obtained a Royal Patent to look into the possibilities of founding a colony, a preliminary voyage had been made, and two Indians of the Algonquian tribe persuaded to return to England. Harriot met these men in London, began to learn their language, and on 1585 April 9, sailed out as what we might call a 'scientist' on the Virginian expedition led by Sir Richard Grenville.

On the 10th day at sea on the eleven-week voyage, Harriot observed a solar eclipse at sunset, although this was really the only astronomically significant aspect of the expedition. Far more important was Harriot's work as what we might now call an ethnologist amongst the Algonquian Indians of the Roanoake area of Virginia. He recorded many aspects of their culture, wrote down their language, inquired into their religious beliefs and became the first teacher of modern western science in North America. For Harriot tells us that he demonstrated a variety of technical devices to the Indians: magnetic compasses, fireworks, burning glasses and a mechanical clock, the tick of which the Indians thought to be a kind of living thing, with a heartbeat. But one of the most curious things which Harriot showed to the Algonquians was a perspective device, by which he demonstrated various 'strange sightes'.³ This has led some people to argue that Harriot possessed some kind of telescope: a device probably related to the optical arrangements described by Leonard and Thomas Digges and other members connected with the Dee

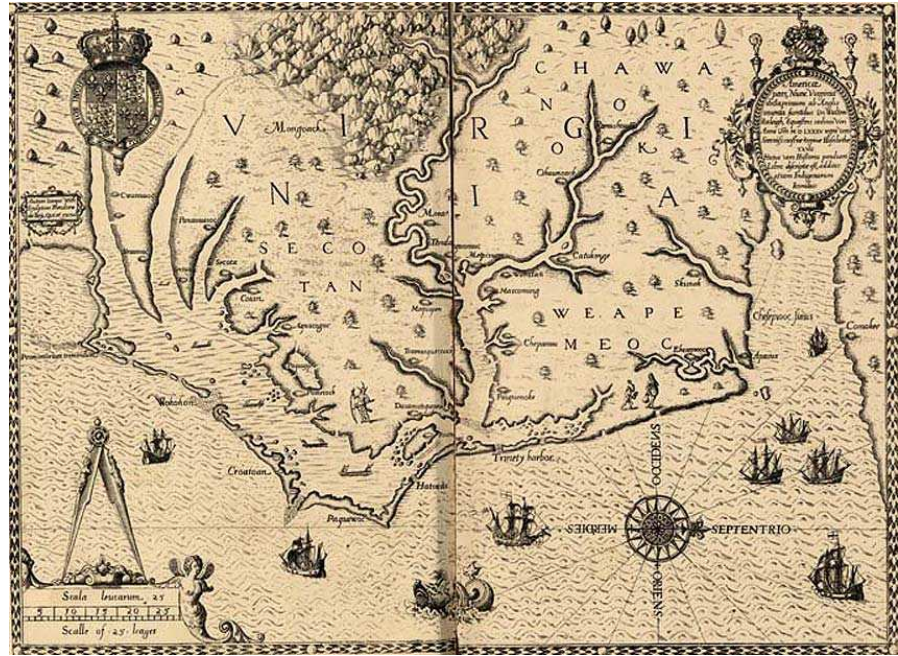

Map of Virginia from Harriot's book '*A Briefe and Trewe Report of the New Found Land in Virginia*', having the caption 'The carte of all the coast of Virginia'. University of North Carolina.

and Raleigh circles. Indeed, was this the 'Tudor Telescope' which was allegedly known only to an inner group of *cognoscenti*, and which preceded Hans Lippershey's 1608 instrument by 30 or 40 years? I will return to the 'Tudor Telescope' presently.

Harriot spent just a year in the Virginia settlement of Roanoake before being brought back to England with the returning fleet of Sir Francis Drake, in June 1586. As a curious coda to this expedition, however, Harriot tells us that the fleet's departure for Plymouth was delayed by a mighty storm that blew in from the sea. The Algonquians told Harriot that it was caused by the terrible storm-god, *Huracan!*

Once back in England, there is no evidence that Harriot travelled again. By 26, he seems to have settled down to the life of an academic mathematician, doing front-rank research. For Thomas Harriot did so much to lay the foundations of modern algebra and analytical geometry. He was a 'retiring' man with that 'melancholy' of temperament which the Tudors associated with thinking types. He was also very comfortably off, being handsomely funded by Raleigh and settling down to the life of an academic bachelor and gentleman in easy circumstances.

His circumstances changed in the 1590s, however, for following Raleigh's fall from royal favour in consequence of his secret marriage becoming public news, Harriot was handed over, in part, to a new patron, as Sir Walter had no wish to see him suffer because of his own fall from grace. This new patron was Henry Percy, the very wealthy Earl of Northumberland, who was also a friend of Raleigh and a patron of mathematicians and scholars. Indeed, from his early twenties onwards, Harriot seemed to have the knack for impressing the rich and famous, and never lacked ample funds. Raleigh had paid him handsomely, and gave him land and rentals, which he had recently seized from the Catholic Irish,

while Percy did likewise, by bestowing upon Harriot rentals from his Northumberland estates, a house in the grounds of Sion Park near Kew (another of the Earl's properties), and probably another house in Threadneedle Street, in the heart of the City of London: the London house in which Harriot died in 1621.

What is more, Harriot seems not to have had any specific job description. Rather, he was paid for being very clever, conversing with the Earl as required, probably advising sea officers about navigational astronomy (as he had done when he was part of Raleigh's 'household') and becoming the leader of the 'earle of Northumberland's three Magi'. The seventeenth century antiquary John Aubrey tells us in his *Brief Life* of Harriot, written 70 years later, that the other two wise men were Walter Warner and Robert Hues. Indeed, Harriot seems to have been a prominent figure in a group of distinguished men who constituted his network of friends. These included the Welsh knight and Cornish MP, Sir William Lower, the Revd. Nathaniel Torporley, the poet George Chapman and Christopher Tooke, Harriot's technician. And of course, there was Lord Percy himself, often nicknamed the 'Wizard Earl' because of his exotic interests, and the continuing friendship and support of Sir Walter Raleigh.

There was, however, a somewhat sinister atmosphere hanging around this group. Raleigh was arrested soon after the accession of the new King James I in the summer of 1603 (Queen Elizabeth I had died in March), sentenced to death, then had his execution stayed but not pardoned. Sir Walter remained in the Tower of London, and was finally beheaded in 1618, witnessed by Harriot. Then in 1605, Henry Percy was arrested on suspicion of knowing about Guy Fawkes' impending Gunpowder Plot and not alerting the authorities. Lord Percy was held in the Tower and was not released until 1621. And through his associations with the Earl, Harriot himself was arrested in November 1605 and confined within the Gatehouse gaol, though released three weeks later.

It is necessary, however, to clear our minds of popular images of the Tower of London, when considering the imprisonment of men like Northumberland, Raleigh, or even Harriot. High-status political prisoners were not chained up in filthy dungeons and occasionally fed on offal. A wealthy prisoner could hire a suite of rooms, usually at a very stiff rent. He was neither chained nor locked in, but often enjoyed the 'liberties of the Tower' in so far as he could come and go as he pleased within the rambling greens, walks, and bastions of the complex. Many civil servants lived in the Tower, the Royal Mint was there, and occasionally, the Monarch resided in the Tower. There were shops, drinking places and a church. Raleigh and Lord Percy walked together and socialised in the Tower, with released friends like Thomas Harriot and his fellow 'Magi' calling in. Percy continued to manage his Northumberland estates while resident in the Tower, and made sure Harriot was comfortable at Sion Park, while Sir Walter brought in his wife and family to live with him, performed chemical experiments in a private laboratory, and wrote his monumental *History of the World* – a work foreshortened by his eventual execution in 1618. For such men therefore, being in the Tower was less about being locked up than it was about being watched and having one's movements restricted.

On the other hand, being detained at His Majesty's Pleasure, no matter how liberally, could never have been conducive to peace of mind. One rarely knew how long the confinement might last, or when one might suddenly find oneself on the way to the scaffold. I suspect that one reason why Thomas Harriot seems so shy about publishing his work, or laying claim to great discoveries, derives from a reluctance to put his head above the parapet in dangerous times. For though Harriot's mathematical and astronomical work was quite innocent politically, there was nothing for him to gain by raising his public profile. Unlike Galileo, Harriot did not seem to desire fame, he was amply rich for all his needs, and he had no intellectual axes to grind, as did Galileo about Copernicanism. A peaceful and intellectually productive life was best enjoyed as a private gentleman, not as a public figure. Besides, it had also been rumoured that he was a religious unbeliever who had doubts about the *Genesis* Creation narrative, although modern studies of his surviving manuscripts in the British Library contain nothing atheistical as such.

Harriot the astronomer

Let it be clearly understood that Thomas Harriot's real passion was mathematics: that fascinating world of absolute and unchallengeable abstract truths that he pioneered in his algebraic studies. Astronomy only really interested him when it became mathematical and dealt with the baffling business of planetary motion. Like several other Tudor scientific men, such as Thomas Digges, and Dr William Gilbert, Queen Elizabeth's doctor, Harriot was attracted to the mathematical elegance of Copernicus' heliocentric universe. It explained the planetary retrogrades so much more simply than Ptolemaic epicycles, for if everything went around the Sun, were there any concentric crystalline spheres that, as had been alleged from ancient times, were necessary to keep the planets rotating? Or was space empty? Dr Gilbert suggested that some sort of magnetic flux from the Sun might well sustain planetary motion: an idea that greatly increased in plausibility in 1610 when both Harriot and Galileo quite independently discovered sunspots by means of their telescopes, and realised *contra* Aristotle, that the Sun was not fixed but had an axial rotation, and that instead of being pure and golden, it was blotched. Could such a solar flux emanate from the rotating Sun and carry the planets in the same direction, and in the same flat plane through space? Johannes Kepler in Prague thought so, and was deeply influenced by Gilbert's writings, while in the 1630s, the Lancashire astronomer, Jeremiah Horrocks thought likewise.

For some thirty years, Harriot made astronomical observations with instruments known generically as 'Astronomical Radiani', which were configurations of long rods fitted with brass sights (see diagram). In this way, one could describe great triangles in the sky, and use them to measure distances between the stars, and between the moving planets and the starry background. Harriot's principal Radian had a 12-foot [3.65m] long main rod that was fixed upon a stand by means

of a flexible joint, so that by means of jointed cross-rods and sights, one could measure off any angle, in any plane of the sky with relative ease. Of course, as one was working with configurations of jointed straight rods, as opposed to 90° curved scales, one did not obtain a direct angle, so much as a series of proportions that could be converted into angles by means of tangent tables. Tycho Brahe and Copernicus had also used instruments working in accordance with the same principles, and with care, they could be used to give reliable measures to within a few arc minutes.

Harriot observed the positions of several comets with such radial instruments, including what we now know to have been Halley's, in 1607, and the spectacularly brilliant and long-tailed comet of 1618.⁴ Indeed, his angular values for Comet Halley in 1607 were so accurate, that over two centuries later in 1808, the eminent German astronomer Friedrich Wilhelm Bessel was able to use them in his great analysis of the comet's orbit.

We must remember that, since Greek times, astronomy had been a mathematical science and not a physical, observational one. Astronomy had been about measuring angles in the sky with graduated instruments equipped with naked-eye sights, and the data thereby gathered was used to build up catalogues. The catalogues in turn were then used to provide data upon which geometrical analyses could be based, to establish the proportions of epicycles, compute calendars, and predict eclipses. Astronomy was *not* about looking at objects in their own right, for until 1609, there was nothing new that the unaided human eye could see. But that changed permanently after 1608 October 2, when Hans Lippershey in Middelburg, Holland, made public his arrangement of lenses which made distant objects appear close. And then, in the summer of 1609, Thomas Harriot used his newly acquired 'Dutch Truncke' to look at the Moon, then Jupiter and the Sun.

When Harriot saw these objects – and he certainly records seeing the Moon, at a magnification of $\times 6$ on the night of 1609 July 26 – he seems to have been entirely surprised by what he saw in that instrument, variously described as a 'truncke' or 'perspective'. The sheer novelty of the views

only confirms my suspicion that there had never been a 'Tudor Telescope', invented by Thomas Digges twenty or thirty years before, and somehow suppressed by the government for state security reasons.

Harriot's telescope

We are not certain from where Thomas Harriot obtained his instrument, but we do know that by 1609, 'Dutch Trunckes' were openly on sale in Holland, Frankfurt, Paris and elsewhere, for Lippershey's patent was never granted and the basic simple design of the 'Trunckes' must have easily leaked out. Ordinary spectacles, after all, were commonplace by 1609, and there must have been hundreds of people across Europe who ground convex and concave lenses on a daily basis. Indeed, numerous portraits and art works from the 15th century onwards survive showing people wearing glasses, especially if they were scholars.

What is more than likely is that the comfortably-off Harriot obtained a simple telescope from Holland, gave it to his technician, Christopher Tooke, had it taken to pieces, replicated, and rapidly improved. A mathematician of Harriot's standing would soon have mastered the optical geometry of the device, and learned how to make instruments that magnified $\times 20$ or $\times 30$ times, as we know he had. And at about the same time, in Italy, Galileo was going through an almost identical process, and building his first telescopes in the summer of 1609. What really is amazing, however, is that the basic lens configuration had not been stumbled upon before, for spectacles and magnifying glasses had long been commonplace.

So why did Harriot choose to look at the moon on 1609 July 26? It has been suggested that he was trying to determine the precise time of quadrature or half-moon, though 26th July was not the date of first quarter (in the Julian calendar 1609 July 28 was the date of first quarter). But first quarter would have been important because at that time the Earth, Moon, and Sun form a perfect right-angle triangle in space, and this, since the days of Archimedes, had been reckoned a useful time to calculate the distances of those bodies. Perhaps a telescope would show a more exact quadrature than could be seen with the naked eye.

Quite simply, however, we do not know what stimulated Harriot to make the observation, though a rough drawing survives in the Harriot papers preserved in the British Library, dated 1609 July 26, and specifying a five-day Moon, which shows a ragged terminator and a shaded sea area. But he adds no commentary or attempt to interpret what he saw, although he clearly considered the observation worthy of record.

Yet the classic early description of the Moon made with a telescope came from Harriot's friend, Sir William Lower, who had obtained an early telescope, perhaps made by Christopher Tooke. Writing to Harriot from his estates at Traventi,

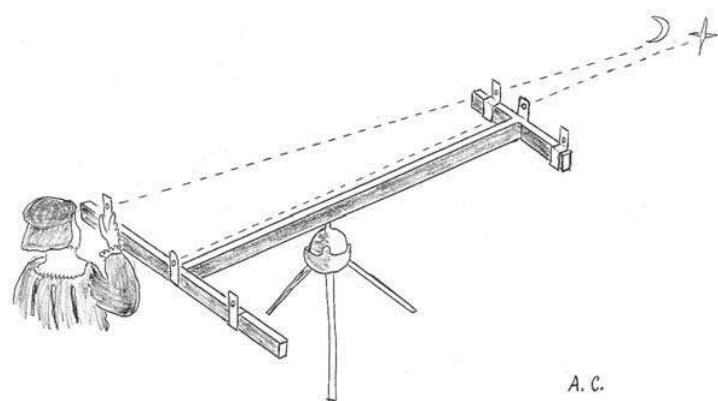

Thomas Harriot's Cross Staff, or Astronomical Radius of 12 feet. The Radius was a common instrument in the 16th and early 17th centuries, and was used to measure celestial angles. Using the fixed sight through the long axis, guided by an assistant, the astronomer would move the sliding brass sights towards the Moon or a star. The graduations on the rods then enabled the angle – in the present example, between the Moon and a star – to be calculated by means of the Rule of Tangents. *Drawing by Dr Allan Chapman.*

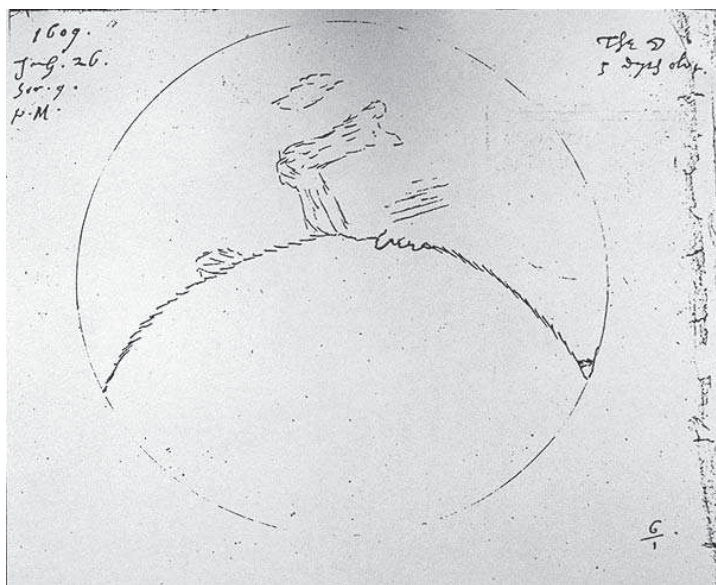

The first telescopic drawing of the Moon, 1609 July 26, by Thomas Harriot. The Moon is 5 days old. One can identify Mare Crisium, Mare Tranquillitatis, and Mare Foecunditatis, and perhaps Lacus Somniorum, as well as the rough terminator.

Carmarthenshire, Wales, on 1610 February 6, Lower exclaimed that the Moon's surface reminded him – '[of] the description of coasts, in the dutch books of voyages. In the full she appears like a tarte that my cooke made me the last weeke. Here a vaine of bright stuffe, and there darke. I must confesse I can see none of this without my cylinder'.⁵ Lower does not tell us when he first acquired the telescope, but it had clearly been long enough ago for him to see the Moon through at least one cycle of phases, and to study its surface carefully.

However, after his initial sketch of 1609 July 26, Harriot did not draw the Moon again, as far as the historical record goes, until 1610 July 17, and by that date he would have had time to read Galileo's *Sidereus Nuncius*, which had been published in Venice in March 1610, and was being commented upon in England by June of that year.⁶ Could it be, as Terrie F. Bloom argues, that while having an unquestioned priority in observing the Moon telescopically, it was Galileo's published drawings and descriptions of the telescopic Moon that had stimulated Harriot's subsequent lunar studies? And once the bit was between his teeth, as it were, and he became more secure in what he was looking at and interpreting, he went on to make 19 lunar drawings, which still survive, some of them much more detailed than those of Galileo.

Yet while there are no surviving Harriot drawings of the Moon between July 1609 and July 1610, it appears, from Lower's letter of 1610 February 6 – written when Galileo was still preparing *Sidereus Nuncius* for the press – that Harriot and Lower were discussing the telescopic Moon, and no doubt observing it. Sadly, there are no extant letters from Harriot to Lower, or any record of conversations between them, for this period.

Harriot also seems to have made an independent discovery of sunspots. It is true that Galileo claimed in his *Dialogue concerning the Two Chief World Systems*, 1632 [tr. Stillman Drake (Berkeley & Los Angeles, 1962) p.345] to have seen sunspots in July or August 1610, though he did not

publish anything on sunspots until 1612–'13; but Harriot recorded in his manuscripts, '1610, Syon December 3rd – [Saturday] The altitude of the sonne being 7 or 8 degrees. It being a frost & a mist I saw the sonne in this manner.'⁷ Harriot was looking directly at the Sun as it rose through thick mist, and observed spots on its surface. Over the next year or so, he recorded no less than 200 other sunspot observations, invariably made by direct vision through thick mist, or through cloud.^{7,8} His notes cover some 73 pages of foolscap paper. Amazingly, Harriot seemed to suffer no damage to his eyes, though a younger Oxford contemporary, Prof. John Greaves, recorded that after observing the Sun by direct vision he saw 'as it were, a company of crows flying together in the air at a distance.'⁹ Perhaps Greaves had permanently damaged his retina! Why Harriot observed directly is not clear, for Galileo and others were using the projection technique right from the start. (And contrary to popular mythology, Galileo's blindness was *not* caused by looking directly at the Sun. He tells us that he observed by projection, 1610 and

onwards, and he did not go blind until he was an old man, in 1636–'37.)

Harriot observed the Sun on 1611 January 19 when, like other astronomers across Europe, he kept watch to see whether Venus would pass across the Sun at inferior conjunction. It did not, and the honour of seeing Venus in transit for the first time in scientific history would go to Jeremiah Horrocks, then living at Much Hoole, Preston, and William Crabtree of Salford, Lancashire, in November 1639.

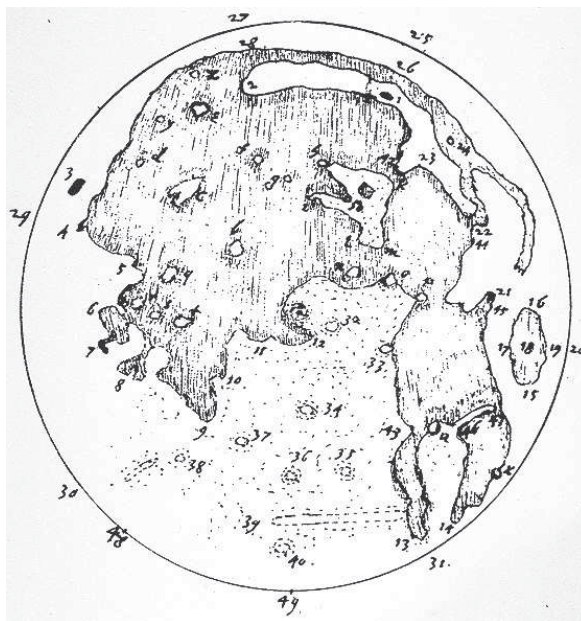

Harriot's drawing of the Moon, probably late summer 1610. Harriot had seen Galileo's drawings in *Sidereus Nuncius* by this date. What especially fascinated Harriot were the lunar seas, which were also commented upon by Sir William Lower. Inspired as Harriot may have been by Galileo's Moon drawings, this map is far more detailed and accurate than any of those of Galileo.

Early telescopic images

While many astronomers were seeing sunspots by 1611 or 1612, and Galileo was to announce his own researches and prior correspondence in *Letters on Sunspots* (1613), which made them public property across Europe, it cannot be denied that Harriot was a very early and entirely independent co-discoverer of the spots. Of course, neither Thomas Harriot nor anyone else really had any idea what the spots were in physical terms, nor would have for another 300 years; but they demonstrated that the Sun rotated upon its axis in about 27 days. And this in itself challenged the Aristotelian idea of the Sun's fixity and changelessness, and seemed to add weight to the Copernican theory.

Harriot's papers also record numerous observations of the satellites of Jupiter. And here, one cannot really claim any priority for his observations, for Harriot did not see all four satellites until 1610 December 14, whereas Galileo had seen them in January 1610, and published his observations in *Sidereus Nuncius* in March 1610. More than likely, Harriot heard or read of Galileo's Jupiter observations before making his own.

It is not clear whether Harriot and his friends who owned telescopes were looking through them at the stars in the Pleiades, Orion's Sword, or the Milky Way before they could have read of them in Galileo's *Sidereus Nuncius*, copies of which were probably reaching England via the well-established European book trade by the late spring of 1610. On the 'longest day' of 1610 [June 13, Old Style], however, Sir William Lower wrote to Harriot from his Welsh residence to report that with his 'cylinder' he could now see seven stars in Taurus [the Pleiades] and three dim ones in Orion's Sword.¹⁰ Of course, these are really naked-eye stars, and their new visibility to Sir William in his 'cylinder' probably tells us more about the state of his unaided eyesight than about the stars themselves, though one picks up the sense of wonder at what the telescope could reveal. (Galileo, however, reported that he could count 40 stars in the Pleiades.)

But let us remember that the Pleiades, and Orion's Sword, are not star groups that one can see on the 'longest day', for they are familiar parts of the winter sky. Lower, therefore, was probably reporting observations he had made during the winter of 1609–10, at around the same time as Galileo was first seeing these stars in Italy, and so could well reckon them as independent discoveries made *before* copies of *Sidereus Nuncius* reached England.

Yet neither Harriot, nor Lower, nor any of their friends who had been given telescopes, published any of these newly-revealed celestial wonders, and they had to wait 223 years before being made fully public. Why no-one published, as we mentioned above, is a moot point, for most of these men were gentleman of standing. But that standing in itself could go towards providing an answer, for in 1610 both Raleigh and Lord Percy of Northumberland were still in the Tower of London, and Harriot had not only been briefly imprisoned following the Gunpowder Plot, but had had his house in Sion Park ransacked and searched for incriminating evidence by King James' agents. Obscurity was probably the best policy, especially if one were well-off and not chasing fame.

Today we are so accustomed to large bright telescopic images, and have such a wealth of guidance about how to interpret what we see, that it is easy for us to forget the sheer puzzlement which the first telescopic images evoked in their observers. For science is not simply about objective 'facts': it is also about the context within which we are obliged to interpret them. And it is clear that in 1609 the first telescopic images of astronomical bodies seemed very confusing and lacking a context in contemporary understanding.

Some years ago, I built a replica 'Galilean' telescope which would have been similar in its optics to the instruments used by Harriot, Lower, and Galileo, with a convex object-glass and a concave eyepiece, although the cheap, mass-produced lenses available to me would probably have been better and more even in figure than those of 1609.

What struck me first, however, was the tiny field of view produced by a 'Galilean' optical system. Not only was it quite an art simply *finding* an object in the sky, but the exit cone of light coming out of the eyepiece was so narrow that getting the image to fall upon one's retina could be quite a feat. It was tricky enough with the Moon, but looking at the planets, or the Pleiades, would have taken a lot of patience and manipulative skill. Though my telescope was only about $\times 15$ in magnification, I was able to get no more than about one-third of the full Moon within the total field at any one time – which helps to explain how early lunar draughtsmen sometimes made conspicuous objects, such as the crater Albatagnius [?], appear too large, or else drew them in the wrong place.

What is plain, however, when reading the accounts of Harriot, Lower, or Galileo, is that the things people saw through telescopes in 1609 were strikingly novel, and had no parallel in previously recorded scientific experience.

Was there a 'Tudor telescope'?

Over the years, various scholars have suggested that those astronomers and instrument makers in and around the Court of Queen Elizabeth I had developed a configuration of lenses and mirrors which made distant objects appear close. Leonard Digges is said by his son, Thomas, to have had some device which enabled him to see people in the street of a distant village, although less convincingly, we are told that he could also use it to read letters in drawers and identify coins several miles away! The Tudor instrument maker William Bourne was said to have built a device with foil-backed mirrors, and my very good late friend Colin Ronan (BAA President 1989–91), and thankfully living friend Gilbert Satterthwaite, built an experimental configuration of lenses and mirrors based on the Digges–Bourne arrangement in 1991, which did indeed furnish a rather aberrated image of distant objects. It was written up in this *Journal*¹¹ and also featured on *The Sky at Night*.

Now as a patriotic Englishman and British to my fingertips, no one would have been more delighted than I at the prospect

of a group of Englishmen inventing the telescope several decades before its official ‘birthday’. But as I said in letters to Colin, as well as in conversation with him and other friends at the time, I simply do not believe that the historical evidence for a Tudor telescope stands up to detailed scrutiny. I also voiced this view at a special meeting of the Scientific Instrument Society which attempted to sift the evidences, held in the rooms of the Society of Antiquaries, Burlington House, London, on 1993 March 26; the proceedings were subsequently published in their *Bulletin*.¹²

In assessing the state of optical knowledge in Tudor England, however, one must remember that no precise terminology for the subject existed. Yes, there was a widespread knowledge, in educated circles, of the optical writings of Ptolemy, Alhazen, Roger Bacon and others, along with a gentlemanly tradition of devising novelties, Automata, and ‘Natural Magick’ shows. But there was terminological ambiguity everywhere. Take the word ‘glass’, for instance. It could, in fact, mean a transparent glass lens, as well as an opaque mirror. In the Old Testament book of *Exodus*, ch. 38 v. 8, for example, in the Authorised Version of 1611, the women of Israel, on the way out of slavery in Egypt, donated their ‘looking glasses’ to be melted down to provide the necessary *brass* to manufacture a liturgical fitting for the Ark of the Covenant. For, as a visit to any good Egyptological museum will confirm, brass and bronze mirrors were the norm in ancient Egypt. Other sixteenth-century references relate to ‘glasses’ made of polished steel. And the Bible translators of 1611 would, like everyone else at the time, have spoken of metal ‘glasses’. This ambiguity, and there are other examples, makes it very hard to interpret precisely sixteenth-century texts which purport to describe optical wonders. ‘Perspective’, moreover, a word used to describe an early telescope, was also used by artists and surveyors to denote the proportionate place of objects in a landscape.

It was, I suspect, such a configuration of ‘glasses’ that Harriot used to generate the ‘strange sightes’ which he showed to the Virginia natives in 1585–’86. For a ‘strange sighte’ could be formed either by a distorting mirror or by a clear lens held at a given distance from the eye. On the other hand, had Harriot a serviceable telescope in Virginia (and considering his friends and contacts back in England, he could easily have built one had they existed), then one might have expected a reference to *magnified* sights.

But, one might say, what if the government back in England had deliberately *suppressed* all knowledge or reference to the fledgling telescope, for state security reasons? All well and good, but I believe that there is a formidable argument against such a ‘conspiracy’ theory. For the very same Thomas Digges that either invented a Tudor telescope, or improved his father Leonard’s prototype, held very high military rank as an officer working under Lord Robert, Earl of Leicester, in the defence of Britain against the Spanish Armada in 1588. Digges produced a study entitled *England’s Defence: A Treatise concerning Invasion: or a briefe Discourse of what Orders were best for repulsing of Foreign Enemies*.¹³ It was clearly intended as a ‘top secret’ document, aimed at senior commanders, magistrates, and government officers. And yet there is not the vaguest hint about

a simple device which gave the strategic advantage of showing *us* the enemy before they knew they were being watched. Would such a valuable device be suppressed for reasons of state? Frankly, I find the idea as implausible as Sir Winston Churchill suppressing radar in World War II, and then expecting no-one to talk or write about it thereafter! For, as any historian will tell you, life and events are just too full of loose-ends and odd contingencies for such smooth and sustained cover-ups to take place in the real world.

Yet to me, the clinching argument against a Tudor telescope must surely be the surprise, if not bafflement, expressed by Harriot, and certainly by Lower, in 1609–’10 when they first beheld the Moon, Jupiter, the Sun, and the stars, through their ‘Dutch truncke’ and its English-made replicas. For no matter what ‘strange sightes’ had been produced previously, here were relatively good, clear images which conveyed a wholly new level of meaning in the universe.

So for these reasons, therefore, I humbly suggest that there was no Tudor telescope.

Conclusion

It had been Harriot and Raleigh, more than anyone else, who learned how to ‘drink’ tobacco smoke in Virginia. And it was they who did much to popularise the habit in England. Of course, we cannot from hindsight blame them for introducing a now-proscribed substance into the country (there had also been Spaniards who had learned tobacco-smoking from American Indians), for tobacco, just like the potato, the tomato, cocoa, or the ‘chocolat’ plant, and quinine bark, was but one of a myriad of natural wonders introduced to Europe from the Americas.

In 1615, Sir Theodore de Mayerne, one of the most distinguished physicians in Europe, and physician to King James I, examined Harriot, and in particular, paid close attention to a growth in his nose. Harriot’s subsequent biographer, John Aubrey, who as a young man in Oxford and in London no doubt met people who had known Harriot personally, recorded in his ‘BriefLife’ that: ‘in the top of his nose came a little red speck (exceeding small) which grew bigger and bigger, and at last killed him. I suppose it was what the Chirurgeians [Surgeons] call a *noli me tangere*, touch me not.’

One wonders whether several decades of inhaling tobacco smoke played a part in Thomas Harriot’s death. He died in his house at Threadneedle Street, in the heart of the City of London on 1621 July 2, aged 61. He was buried in his nearby Parish Church of St Christopher-le-Stocks. The Bank of England now stands on the site of St Christopher’s, which was destroyed in the Great Fire of 1666. Fortunately, however, a copy of Harriot’s tombstone inscription survived, and in 1971 its words were re-engraved upon a bronze tablet, and the tablet placed on a wall within the Bank, at a spot close to where he is said to have been buried.

In the 20th century, Harriot’s voluminous manuscripts, most of which are deposited in the British Library, have received a great deal of attention from scholars, and we are all

indebted to the pioneering researches of Prof. John W. Shirley, of the University of Delaware. Indeed, Harriot and his world have now become the focus of a scholarly 'industry', as he has become the subject of lectures and conferences in Great Britain and in America, and the originality of his mathematical work has come to be recognised.

But on this 400th anniversary of the invention of the telescope, it is important to bear in mind that Thomas Harriot was the first person to use the instrument for astronomical purposes, even if the recognition of his achievement had to wait some two centuries, until the time of de Brühl and von Zach in the 1780s, and for a fuller acknowledgement, until that of Rigaud in 1832–'3. And while Harriot is now securely recognised as one of the greatest mathematical scientists of the Renaissance, we should not forget that it was in Sion Park, and at Traventi, in South Wales, that mankind first saw the heavens as they had never been seen before.

Acknowledgments

I am particularly indebted for the editorial reworking of my speech-recorded lecture into its present published form, to the skill and patience of my wife, Rachel, and to Dr Richard Miles without whose skill and care this text would not have been possible.

Address: Dr Allan Chapman, Wadham College, Oxford OX1 3PN.

References & notes

- John M. Dudley, 'A Tale of Two Portraits: A Note on Two Alleged Images of Thomas Harriot', *The Harrioteer: The Newsletter of the Thomas Harriot Seminar*, University of Durham, April 2000
- Arthur Herman, *To Rule the Waves. How the British Navy Shaped the Modern World*, Hodder & Stoughton, 2004; 92–93
- Thomas Harriot, *A Briefe and Trewe Report of the New Found Land in Virginia* (1588), edited by Harry Stevens, London, 1900; 57
- John Roche, 'The Radius Astronomicus in England', *Annals of Science* **38**, 1–32 (1981)
- Stephen Peter Rigaud, *Supplement to Dr Bradley's Miscellaneous Works with an Account of Harriot's Astronomical Papers* (Oxford Univ. Press, 1833). Printed originally as an Appendix to Rigaud's *Miscellaneous Works of Dr James Bradley* (Oxford Univ. Press, 1832); 42
- Terrie F. Bloom, 'Borrowed Perceptions: Harriot's Maps of the Moon', *Journal for the History of Astronomy*, **ix**, 117–122 (1978)
- Rigaud, *op.cit.*; 32
- John D. North, 'Thomas Harriot and the first telescopic observations of sunspots', in Shirley, *Harriot, Renaissance Scientist*, 129–165
- John Greaves, *Miscellaneous Works II* (London, 1737), but dating from the early seventeenth century; 508
- Rigaud, *op.cit.*; 25–26
- Colin A. Ronan, 'The origins of the reflecting telescope', Presidential Address, *J. Brit. Astron. Assoc.*, **101**(6), 335–342 (1991)
- 'Was there an Elizabethan telescope?', *Bulletin of the Scientific Instrument Society* **37**, 2–10 (June 1993)
- Thomas Digges, *England's Defence: A Treatise concerning Invasion...* Written in manuscript in 1599, but probably originally from the time of the Spanish Armada, 1588. Published 1686 (London). Bodleian Library copy 'Nich.newsp.2(155)'. This Tudor work seems to have been published on several occasions of national crisis. 1686 was significant, as the current crisis was King James II's attempts to catholicise Protestant England, perhaps using a French army.

Additional bibliography & sources

- John Aubrey, *Brief Lives*, edited by Oliver Lawson Dick (London, 1975)
- Allan Chapman, 'The astronomical work of Thomas Harriot', *QJRAS* **36**, 97–107 (1995)
- Allan Chapman, 'The English Copernicans', in *2008 Yearbook of Astronomy*, eds. Sir Patrick Moore & John Mason, Macmillan, London, 2007, 300–311
- Allan Chapman, 'The birth of the telescope', *BBC Sky at Night Magazine*, Sept. 2008, 25–31
- Thomas Digges, *A Perfit Description of the Caelestiall Orbes*, added as a supplement to Leonard Digges' *A Prognostication Everlastinge* (London, 1576, 1585)
- Stillman Drake, 'Galileo's First Telescopic Observations', *Journal for the History of Astronomy*, **vii**, 153–168 (1976)
- Peter French, *John Dee. The World of an Elizabethan Magus* (London, 1972)
- Galileo Galilei, *The Starry Messenger (Sidereus Nuncius)*, 1610; *Excerpts from Letters on Sunspots*, 1613; included in *Discoveries and Opinions of Galileo*, edited by Stillman Drake (Doubleday, Anchor, New York, 1957)
- William Gilbert, *De Magnete* (London, 1600), transl. P. Fleury Mottelay (1893), now in facsimile (Dover Publications, New York, 1958)
- F. R. Johnson, *Astronomical Thought in Renaissance England* (Baltimore, 1937)
- Henry C. King, *History of the Telescope* (London, 1955)
- J. A. Lohne, 'Thomas Harriot', *Dictionary of Scientific Biography* (New York, 1972)
- Antonia McLean, *Humanism and the Rise of Science in Tudor England* (Heinemann, London, 1972)
- David Quinn, 'Thomas Harriot and the New World', in Shirley, *Harriot, Renaissance Scientist*, 36–53
- John J. Roche, 'Thomas Harriot's Astronomy', Oxford University unpublished doctoral thesis (1977), Bodleian Library, Oxford.
- John Roche, 'Harriot, Galileo, and Jupiter's satellites', *Archives Internationales d' Histoire des Sciences* **32**, 10–51 (1982)
- John Roche, 'Thomas Harriot', *Oxford Dictionary of National Biography* (Oxford Univ. Press, 2004)
- Colin A. Ronan, 'Leonard and Thomas Digges', *Endeavour*, New Series, 16 no. 2, 91–94 (1992)
- John W. Shirley, *Thomas Harriot, Renaissance Scientist* (Clarendon Press, Oxford, 1974)
- John W. Shirley, *Thomas Harriot. A Biography* (Clarendon Press, Oxford, 1983)
- Henry Stevens, *Thomas Harriot, the mathematician, the philosopher and the scholar* (London, 1900)
- Ewen A. Whitaker, 'Galileo's Lunar Observations and the Dating of *Sidereus Nuncius*', *Journal for the History of Astronomy*, **ix**, 155–169 (1978)
- E. A. Whitaker, *Mapping and Naming the Moon. A History of Lunar Cartography and Nomenclature* (CUP, 1999)
- Antony à Wood, *Athenae Oxoniensis*, vol. I, 2nd edn. (London, 1721)
- D. K. Yeomans, *Comets. A Chronological History of Observation, Science, and Folklore* (New York, 1991)

President: Sir Patrick Moore, members world-wide
Publications about the Herschel family
Free admission to the Herschel Museum of Astronomy
Twice yearly journal 'The Speculum'
Public Lectures on astronomy & space

The William Herschel Society

19 New King Street, Bath BA1 2BL, UK

where William Herschel discovered Uranus in 1781
Membership £10 pa, UK & Europe, £13 elsewhere

For details write or visit www.williamherchel.org.uk
or email fredsch@tiscali.co.uk or ring 01225 446865