

THE SURECA BIT-10 LONG DURATION BALLOON MISSION: A SUCCESSFUL QUALIFICATION TEST FOR A NEW IRIDIUM[®] TELEMETRY

D. Spoto⁽¹⁾, N. Auricchio⁽²⁾, K. Boen⁽³⁾, A. Calandrino⁽¹⁾, A. Cardillo⁽⁴⁾, E. Caroli⁽²⁾, S. Cortiglioni⁽²⁾, R. Ibba⁽⁵⁾, L. Marchini⁽⁶⁾, A. Orzelli⁽⁷⁾, E. Ronchi⁽⁷⁾, A. Zappettini⁽⁶⁾,

⁽¹⁾ Agenzia Spaziale Italiana, S.S. 113 C.da Milo 91100 Trapani, Italy, Email: domenico.spoto@asi.it

⁽²⁾ INAF/IASF-Bologna, Via Gobetti 101 - 40129 Bologna, Italy, Email: caroli@iasfbo.inaf.it

⁽³⁾ Andøya Rocket Range-P.O. Box 54 - N-8483, Andenes, Norway, Email: kjell@rocketrange.no

⁽⁴⁾ CNR/ISTI Via G. Moruzzi, 1 - 56124 Pisa, Italy, Email: andrea.cardillo@isti.cnr.it

⁽⁵⁾ Agenzia Spaziale Italiana, V.le Liegi, 26 - 00198 Roma, Italy, Email: roberto.ibba@asi.it

⁽⁶⁾ CNR/IMEM, Parco Area delle Scienze, 37/A, 43124 Parma, Italy, Email: zappettini@imem.cnr.it

⁽⁷⁾ LEN S.r.l., Via S.Andrea di Rovereto 33 C.S. - 16043 Chiavari (GE), Italy, Email: len@len.it

ABSTRACT

On June 17th 2010 at 20:30 (UTC) a Long Duration Balloon has been launched from the Nobile Amundsen base (76° 31' 26.0" N 84° 30' 55.4" W, Svalbard Islands) carrying on board the most recent Iridium[®] telemetry module built by an Italian factory in collaboration with an Italian research institute. The payload landed successfully on June 20th 2010 at 21:00 58 (UTC), 76° 30' 44.2" N 84° 40' 31.1" W, about 280 m a.s.l. The Bi-directional Iridium Telemetry (BIT) represents the last application of a prototype module (MSITel) whose development began years ago. A small CZT detector has been used to allow full testing of the scientific input channel. The BIT telemetry provided a true real time control and monitoring of the whole payloads through a full duplex Iridium link, all over the flight, including the ballast release and the flight termination. This BIT unit was able even to take pictures using two onboard webcams that were packed and sent to ground in low resolution mode. All the data has been stored into on board memory sticks and recovered for complete post flight data analysis. The SURECA BIT-10 mission, that once again has demonstrated the capabilities and the reliability of the MSITel module, has accomplished thanks to the joint effort of the Italian Space Agency and the Andøya Rocket Range that made feasible Long Duration Balloon flights from Northern Polar Region.

1. INTRODUCTION

Since many years high altitude balloon flights have provided scientists an alternative to more expensive, even in terms of realization time, satellite based experiments. Flight durations have been growing from few days to several weeks of recent Long Duration Balloon (LDB) flown from Antarctic regions, and plans are underway to provide missions up to months (Ultra LDB) [1].

To keep up with this evolving scenario, it is necessary to provide new communication systems, the so called Over-The-Horizon (OTH) communications. The payload weight and complexity grew as well, requiring continuous updates of subsystems. In addition, the most favorable regions for LDB are Arctic and Antarctic polar areas, where ground based infrastructures are difficult to be realized and operated.

In this framework a flexible and modular approach able to exploit the available satellite global coverage network, in order to guarantee real-time continuous bi-directional links has been adopted. In fact since 2000 year, an Italian team has began to develop a system [2, 3, 4] able to provide up to 4.8 kbps real time bi-directional link for payloads onboard stratospheric balloons, to fulfill the requirements of Long Duration Balloons from Polar regions, where ground infrastructures are often absent and/or rare.

The apparatus has been customized and tested for using the Iridium[®] satellite network, even though it can be easily adapted to any other network communication system. The last version of the equipment, in its basic flight configuration, has two Iridium[®] modems and provides full duplex Telemetry and Telecommands capabilities together with several I/O channels, onboard data storage, backup Li-Ion batteries, two GPS units, in a compact waterproof (IP66) aluminum box. A software package for full control, data management, quick-look of both scientific and housekeeping (HK) data by a Ground Station (one or more PC laptops in TCPIP) that can be operated from everywhere was also implemented.[5]

A first prototype of this BIT (Bi-directional Iridium Telemetry) telemetry module has been used successfully as piggy back of the So.Ra. payload [6] and performed very well during the whole flight, which was from Svalbard Islands to Canada in Summer 2009. More recently another of these system has been flown as primary telemetry unit during the Svalbard balloon launch campaign managed by ASI in collaboration with

ARR in the summer 2010. BIT is based on the MSITel module, whose main features are described hereafter, that has been developed by LEN srl (www.len.it) in collaboration with INAF/IASF-Bologna. The main target of the 2010 flight was to perform a full qualification test of the BIT/MSITel system in operational conditions.

In the following section, we present the payload description, the operations, and the analysis of the data collected and received during the flight, as well as the performances of the apparatus.

2. THE SURECA BIT-10 PAYLOAD

The Sureca BIT-10 payload was constituted of four different subsystems:

- The scientific payload: CZT sensor, PC104, and two webcams;
- The telemetry system: the MSITel module;
- The navigation instrumentation: pyro and ballast systems, ARGOS, Radar Reflector-Flight Train;
- The battery packages

An external power relay board was used to drive the ballast and pyro commands (each of them had a dedicated battery package). The telemetry system functions were performed by the MSITel module in its BIT configuration, establishing the link with the Scientific and the Navigation instrumentation. MSITel was also in charge to switch ON/OFF (each separately) the Scientific instruments and to acquire data from the CZT detector and from webcams, through the PC104 unit. Two GPS units provide the balloon position while a separate ARGOS system was used as support for the payload position knowledge (active redundancy). A passive Radar Reflector has been also used in order to track the payload during the flight. All of these subsystems were supplied by dedicated battery packages. In the following sections both the Telemetry system and the scientific payload with a results summary are described in more details.

3. THE TELEMETRY SYSTEM (MSITEL-BIT)

The BIT telemetry unit (Fig. 1) is a custom version of the MSITel module [4,5,6], a Control Telemetry Unit designed and tested to match the requirements of a system to be used onboard stratospheric balloons. Its design allows interface with one or more intelligent I/O units, like those realized in cooperation with the INAF-IASF Bologna, as well as different user provided instrumentation.

MSITel (MultiSource Intelligent Telemetry) provides the remote control through any available satellite network system using a specific data modem. All the satellite systems are supported, such as Iridium, Inmarsat, Globalstar, Thuraya and any other communication systems because MSITel is easily adaptable to all modems that are *AT command*

compatible up to bit-rate of 19200 bps. No h/w changes are needed but only the s/w shall be modified. The version used in the Sureca BIT-10 mission has been optimized and tested for Iridium platform, which is the one able to guarantee full coverage all over the World. The Iridium modems are by NAL Research (mod.



A3LA-D).

Figure 1. The BIT telemetry system

MSITel has 2 GPS units integrated with external antennas and several I/O, both analog and digital, for a direct control of external instrumentation. Six digital outputs are 0.5 A actuators, managed with a *high security* hardware and software logic and suitable for no-back operation such as balloon-payload detachment (flight termination), ballast release, etc.. All digital inputs are protected against extra voltages and integrated for a time (adjustable) of 10 ms. All the external instrumentation communicates with MSITel through RS232 or RS485.

The MSITel/BIT main features are summarized below:

- Management of two Iridium (or Hayes compatible) modems, that can set to operate either in *backup mode* (2400 bps) or in *split mode* (4800 bps);
- Management of two integrated GPS units;
- Management of an automatic End Mission system, which ensure the start of the payload descent procedure even if connection problems occur;
- Polling of the external instrumentation both by direct user commands or by user defined instructions. All communications are carried out through serial line connection (RS232 or RS485);
- One up to 115 Kbps serial port, dedicated to scientific data, operating either in *burst mode* or *on-demand mode*;
- Two serial channels, dedicated to housekeeping data from external instrumentation, operating in *on-demand mode*;
- Data acquisition of the local I/O according to the macro-language instructions (MTL);
- 6 digital outputs, reed relais buffered, max 0.5A;
- 8 digital inputs (0-5 V);

- 6 digital output, buffered, max 100 mA @50V;
- 2 analog outputs 10mA @6 V max;
- 4 analog inputs, 5 V full range
- Storage of the acquired data into Compact Flash;
- Sending of the acquired data to the Ground Station with a special protocol, according to the meta-language instructions (down-link telemetry);
- Execution of commands received by the Ground Station (up-link telemetry);
- Management of data to be addressed to other onboard (external) units;
- Very low power consumption, 250 mA in standby mode @12V.
- backup power supply in case of failure of the main external battery package (a Li-Ion buffer battery).

The main specifications of MSITel system are:

- Power Supply Voltage range: 9÷40VDC;
- Operating Temperature range: -40°C to +50°C;
- Operating pressure: tested from 1000 mBar down to ≤1mBar;
- Unit size: 323 mm×189 mm×35 mm (mainboard); 410 mm×315 mm×155 mm (MSITel box);
- Weight: 8.6 kg (IP66 box which includes 2 modem and buffer batteries)

Furthermore MSITel system is available in different versions and it is easy customizable.

All the data acquired by the unit, even if not transmitted according to user defined priority rules, are stored in compact flash cards (up to 8 Gbytes). MSITel makes use of a *real-time clock*, synchronized with onboard GPS, to provide absolute timing for the data storage. This provides a safe time correlation for all stored events. The connection with the Iridium modems (both the master and the back-up units) is provided by a 9-wire RS-232 serial line (hardware handshake). The power supply to each modem unit is provided separately. The bandwidth (bit-rate) can be doubled by using both the onboard modem units (*split mode*), simultaneously. The MSITel board unit has also additional sensors for monitoring Power Supply Voltage, internal VDC and the unit actual temperature.

The MSITel allows extended function customization according to user defined instruction (by meta-language scripts - MTL) and up to six MSITel modules can be used to have higher (up to 28800 bps) telemetry bit-rate by using an additional unit (available by LEN).

Since the BIT system have to manage the scientific data coming from the CZT detector and the two webcams, the basic module was equipped with a PC104 unit operating as *scientific data central manager*.

After the switch ON of both the PC104 and the CZT sensor by a proper telemetry command, the Ground station user asks either for CZT or webcam image data BIT, which forward the request to the PC104 (Fig. 2).

Each event arriving from the CZT detector is stored in a packet (each packet contains up to 190 events). When at least a packet is full the PC104 sends it to MSITel (if

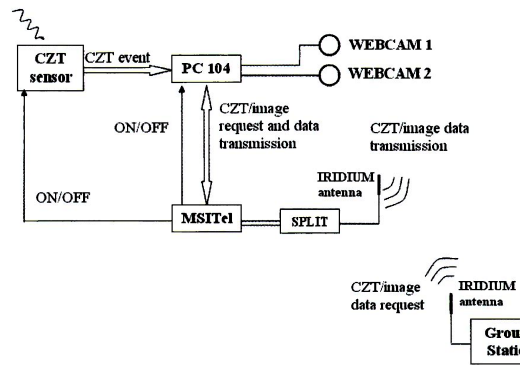

requested), which provides to send it to ground stations and to store the data in the compact flashes.

Figure 2. The scientific payload organization

If the user asks for an Image the PC104 will acquire an image from the selected webcam and sends data packets when requested (On Demand protocol).

4. THE SCIENTIFIC PAYLOAD

The scientific payload included a high energy radiation detector based on a CZT sensor made by IMEM/CNR-Parma, using material developed and grown by the same group, and an interface module generating an RS232 data stream that could be directly connected to one of the BIT telemetry serial port (Fig. 3).

The sensor, with planar mono-electrodes, is a CZT crystal of $1.6 \times 1.4 \times 0.2 \text{ cm}^3$ implemented in a small metallic box providing both light and electromagnetic shielding and containing:

- The high voltage (up to 1200 V) supply for the CZT sensor based on a EMCO DC-DC converter;
- The analogue readout chain of the detector signals based on CREMAT hybrid devices: a charge sensitive preamplifier CR-110 and a shaping amplifier CR-200.

The sensor box has a 9-pin tray connector for power supply (+/- 12 volts) and a BNC connector for analog

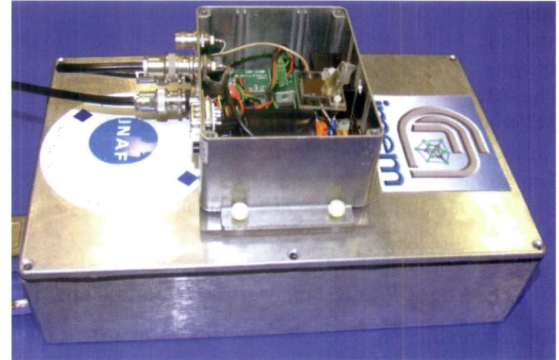

signal output.

Figure 3. The detector system: the CZT sensor (visible on the right) box screwed on top of the interface unit.

The sensor box has a 9-pin tray connector for power supply (+/- 12 volts) and a BNC connector for analog signal output.

On the same side a trimmer screw for adjusting the high voltage and a jack for the monitor of the HV are available. The CZT sensor is normally operated between 200 and 400 volts.

A separate box contains the interface module that get the signal output (in volts) from the sensor module, discriminates the signals above a selected threshold and integrates them over a defined time. Then it sends, by RS232 communication, the number of counts per second to the corresponding connector of BIT.

This scientific instrumentation had two main purposes:

- To determine the count rate from 30 to several hundred keV of X/gamma and charged particles as a function of latitude and longitude and as a function of altitude.
- To verify the performance and the robustness of CZT sensors developed entirely with Italian technology in a pseudo space environment and to assess their suitability for the realization of compact space radiation monitors.

5. THE SURECA BIT-10 FLIGHT REPORT

The payload was successfully launched using a 30.000 m³ balloon on June 17th 2010 at 20:30 (UTC) from the Longyearbein airport and reached the floating altitude of 39400 m at 22:22:13 (UTC).

The flight continued following a regular schedule till June 20th 2010 at 20:14:12 (UTC) when the end-of-flight sequence was sent and the payload descent sequence began at 76° 31' 26.0" N 84° 30' 55.4" W. The payload landed on June 20th 2010 at 21:00:58 (UTC), 76° 30' 44.2" N 84° 40' 31.1" W, about 280 m a.s.l.

During the whole flight, periodical connection with the BIT module were performed to monitor the situation. In the flight phases that were considered *safe* Iridium connections were taken short (few minutes each two hours). Soon after landing the Iridium connections were lost due to the resulting bad position of the Iridium antenna.

The ARR Recovery team started their travel on June 24th to the recovery area in the Nunavut territory in the Northern Canada, more than 3500 km north of Ottawa. The payload was successfully recovered on June 28th and the team and the payload were back in Resolute Bay the same night.

5.1. The Flight Prediction, Monitoring and Control

Flight prediction, monitoring and control were performed by SURECA Mission Operation Team (MOT) at Nobile Amundsen Mission Operation Control Center (MOCC). Trajectory predictions were made

every twelve hours at MOCC by using the ASI Trajectory Prediction Subsystem.

The numerical input weather prediction parameters were coming from the Global Forecast System Atmospheric Model running at the USA National Centers for Environmental Prediction (NCEP), an arm of the NOAA's National Weather Service. The original data were adapted to the ASI subsystem at the University of L'Aquila in Italy, and received at MOCC via FTP. The balloon altitude predicted data, also required as input, were generated by the MOT.

Actual flight parameters (trajectory and altitude included) were displayed by both MSITel ground station and the ASI flight monitoring and control system. The ASI system, receiving GPS data from MSITel ground station via RS232, has been used as primary; in any case no discrepancies were found between the two systems in the monitoring of the flight parameters. The SURECA BIT-10 balloon actual

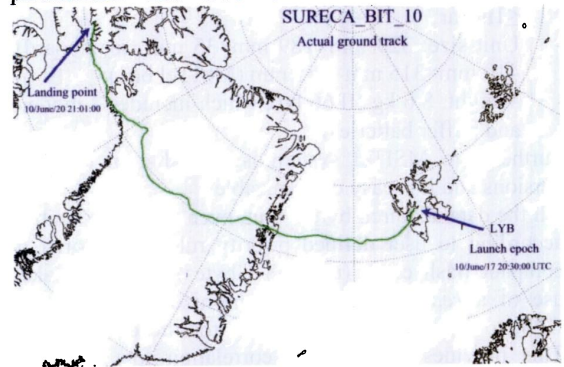

trajectory is shown in Fig. 4.

Figure 4. Trajectory prediction performed four hours before landing

6. DATA DECODING AND ANALYSIS

After the payload recovery the data recorded into the on board compact flash memory were decoded and compared with the data transmitted by BIT during the flight to check their consistency.

As an example of HK data analysis, Fig. 5 reports the temperature of the BIT main board registered during the flight (dark blue line); red dots give the sun elevation degree reconstructed off-line. The blue background bands represent the periods when the payload was flying over the sea, while red squares correspond to periods in which the Scientific instrumentation was ON.

After the float altitude is reached at about 39000 m., the payload oscillates around this value for approximately 24 hours. Then, probably due to weather conditions, the float altitude begins to decrease and shows larger variations. The same unexpected weather conditions were probably responsible also for a drastic changes in the direction of the balloon flight with respect to

expectations (see region inside the orange circle in Fig. 6, bottom panel).

In top panel of the same figure is clearly visible on the right the moment of the payload release and the

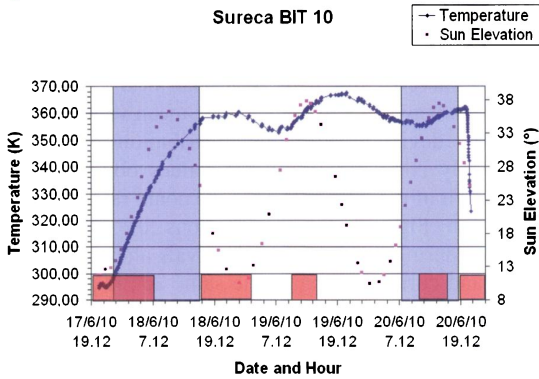

subsequent descent toward ground.

Figure 5. BIT motherboard temperature during the flight in relation with the Sun elevation, the scientific instrumentation ON periods (red boxes) and navigation

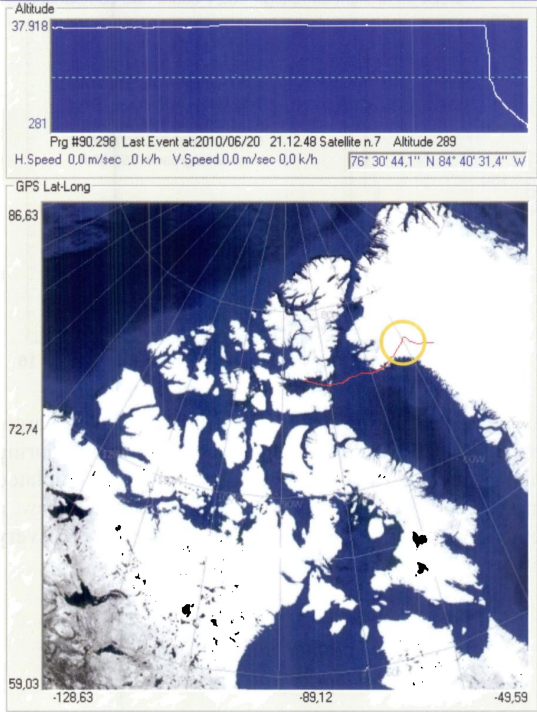

over sea regions (light blue bands).

Figure 6. Real time display of HK data transmitted by BIT module; (top panel) the balloon altitude in meters; (bottom panel) the corresponding balloon trajectory .

6.1. Images from onboard webcams

During the flight, users were able to obtain real time pictures recorded from 2 on board webcams. This was possible by simply sending a telemetry command to the BIT module, which managed the interface with the PC104 unit, took a photo from the webcam and sent it through the Iridium connection in a compressed format. Samples of downloaded pictures taken at different phases of the SURECA-10 flight are reported in Fig.7 and Fig.8.

The possibility of seeing what happen on the balloon or



on the payload during the flight may be of great interest both for the scientific and from the navigation point of view, allowing a direct control of the situation.

Figure 7. Webcam picture downloaded during the flight,

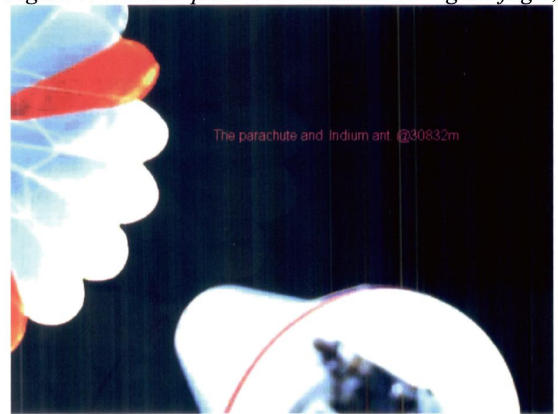

when the payload was at an altitude of ~38.5 km; it is possible to see the balloon and the Iridium antenna, with the black sky in the background.

Figure 8. Webcam picture downloaded during the descent phase, when the payload was at an altitude of 30.8 km; it is possible to see the parachute and the Iridium antenna over the black sky background.

6.2. Scientific data analysis

During the entire flight the CZT sensor system remains perfectly functional and operative and was able to record the background count rate profile of both particles and photons (40-400/500 keV) at arctic latitudes for several hours (~28 h) along all the balloon orbit. The CZT sensor unit has continued to accumulate data through the PC-104 on the on board compact flash also after landing for about 16 hours. As demonstrated

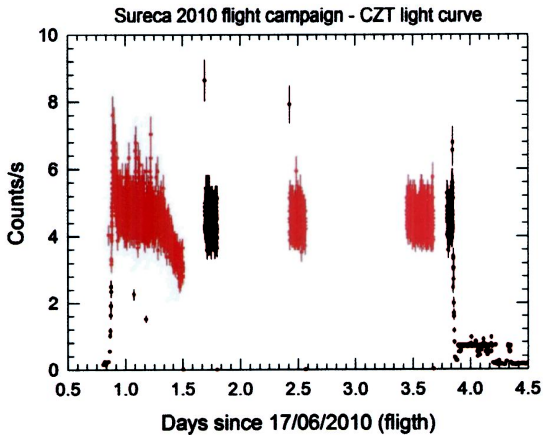

by data reported in Fig.9, the count rate was almost constant during all the flight. Only in the first part after arriving at the float altitude a slow (16 hours) decrease in count rates is visible.

Figure 9. The CZT count rates measured during the SURECA-10 flight.

This variation will be explained by a deeper analysis and in particular it can be correlated with some environmental parameter such as the balloon quote. The uniformity of the count rate at float altitude is further demonstrated by Fig. 10 that shows the count

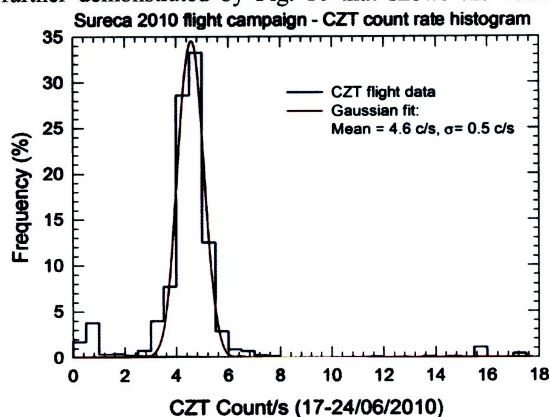

rate distribution obtained from data recorded during all the flight including the data acquired after landing. The

count rate distribution is consistent with high statistical significance to a constant value of ~4.6 c/s.

Figure 10. Histogram of count rates over all the flight including the data acquired at ground after landing.

The red curve represent the Gaussian best fit obtained using data between 2 and 8 c/s. The mean value and the standard deviation of the distribution are both statistically compatible with the values obtained by a constant fit of the time profile of the count rate.

Finally in Fig. 11 the distributions of count rates recorded during different time intervals along the entire flight, and corresponding to the same active periods of the CZT detector reported in the light curve of Fig. 7, are shown in order to compare their characteristics.

This figure again confirm the uniformity of detected count rate along the balloon track.

This is very evident for measurement intervals from the 2nd (1.8 days from launch day) to the 5th (3.9 day from launch day). All these distribution have statistically consistent moments. The distribution accumulated from

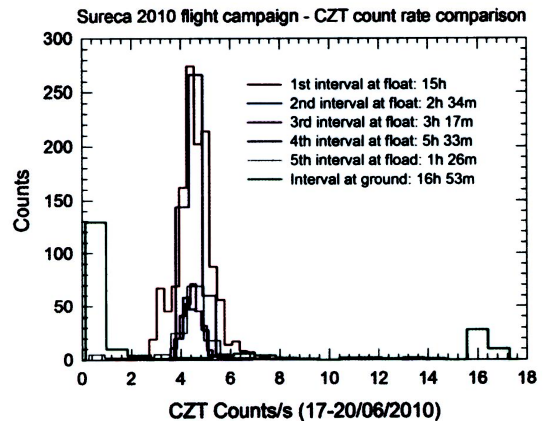

data recorded during the 1st flight interval have a larger variance due to the systematic decrease of count during this 15 hours period, while the distribution accumulated on ground after the payload landing clearly show a bimodal shape due probably noise increase in the very last period of data accumulation.

Figure 11. The count rate values distribution in different accumulation interval along the flight.

7. CONCLUSIONS

The 2010 SURECA BIT-10 flight has definitely demonstrated the reliability of the BIT telemetry, that was already used successfully in the 2009 SIDERALE flight, also from Svalbard [7,8]. The extended capabilities of the BIT module used in the 2009, were the former BIT version provided more than 4 days of continuum real time link that was used both for the

SIDERALE experiment and for the ballast management, has been improved in the 2010 version. Thanks to that BIT was able even to send some pictures taken by two standard web cameras: one pointed to the vertical sky and another towards the ground. All the pictures were stored into the internal BIT Flash memories while some of them were sent in a compressed format to the Ground Station console, from where it was possible to have a look of the balloon chain during flight termination and landing phases. As in the previous 2009 flight BIT has enabled multiple Ground Station (secondary) consoles, connected via Internet to the main Ground Station, from where experiment and flight data were monitored in real time. The new Ground Station software has offered better user interface to the flight team as well to the science team. Due to the environment Summer Polar conditions at stratospheric altitudes the temperature inside the BIT box has reached peak values of more than 90 °C (see Figure 5) and mean value around 80 °C. These conditions are well beyond the BIT specifications as well as those of NAL Iridium modems. However, besides of some short Iridium link interruptions, especially during last flight phases, the BIT module performed always as expected. After payload recovery it was possible to download all the BIT stored data successfully for a complete analysis of both flight and science data. A quite light refurbishment allowed to have the BIT unit ready again to fly in a next campaign. In summary, the availability of a commercial Telemetry unit like BIT really opens a new scenario for the circumpolar flight of even complex payloads. The maximum (2×2400 kbps) bit-rate of each BIT unit can allow a real time management of a sample of most important payload parameters, while all the data can be safely stored into onboard solid state memory. The high level of customization of the MSITel basic module may allow even higher bit-rate, if needed, by coupling more MSITel modules. For more details of the MSITel module family as well as on the most recent release see the LEN web site (www.len.it).

8. REFERENCES

1. Cathey Jr., H.M. (2009). The NASA super pressure balloon – A path to flight. *Advances in Space Research* **44**(1), 23-38.
2. Cortiglioni S. et al (2003). Bar-SPOrt: An experiment to measure the linearly polarized sky emission from both the cosmic microwave background and foregrounds. *Proc. 16th ESA Symp. on European Rocket and Balloon Programmes and Related Research* (Sankt-Gallen, Switzerland) ESA-SP 530, 271-278.
3. Ramponi M. et al. (2005). A new modular system for telemetry-telecommand continuum link and power supply in long duration balloon flights. *Proc. 17th ESA Symp. on European Rocket and Balloon Programmes and Related Research* (Sandefjord, Norway) ESA-SP 590, 413-418.
4. Ronchi E. et al. (STRADIUM Coll.) (2008). STRADIUM: A telemetry and telecommand system for LDB flights, *Mem. SAIItMem. S.A.It.*, **79**, 926-931.
5. Cecchini S. et al. (2009). A Full Duplex telemetry system for long duration stratospheric balloons. *Proc. 19th ESA Symp. on European Rocket and Balloon Programmes and Related Research* (Bad-Reichenhall, Germany) ESA SP-671, 239-244.
6. The SoRa (Sounding Radar) mission: link at www.corista.unina.it/sorae.html.
7. Quadrini E.M. and Caroli E. (2008). CZT detector technological development and balloon testing. *Mem. S.A.It.* **79**, 867-871.
8. M. Alderighi, et al. (2010). SIDERALE and BIT: a small stratospheric balloon experiment for polar gamma background. *Proc. of SPIE*, Vol. 7732, 773232/1-9, doi:10.1117/12.862710